

We UVCare...



Application Optimized UV for Pharmaceuticals

PHARMALINE PQ AF



Bioassayed UV
disinfection for
pre-treatment
process water

Our PharmaLine PQ AF systems are aimed specifically at providing third party bioassayed UV disinfection for Purified Water Generation System Pre-treatment where sanitary design is not critical. By using a third party bioassayed UV system you can be certain that the UV dose being produced will disinfect the water, eliminate objectionable organisms, reduce the bio-burden, protect against bio-fouling, lead to fewer CIP / SIP cycles and lower operating costs. Each system comes with a certified dry UV sensor and UVGuard™ sensor window allowing easy checking of UV performance while the system continues to operate. The UV sensor measures the germicidal output of the UV system and a UV dose read out makes it easy to monitor and log performance. The systems all use low pressure amalgam lamps providing an energy efficient germicidal wavelength, long lamp life to reduce operating costs and can be easily installed to existing processes. The control system also has the ability to take flow and transmittance meter inputs and calculate the UV dose based on real time operating conditions.

berson

hanovia

aquionics

The Operating Cycle of the PharmaLine PQ AFT™

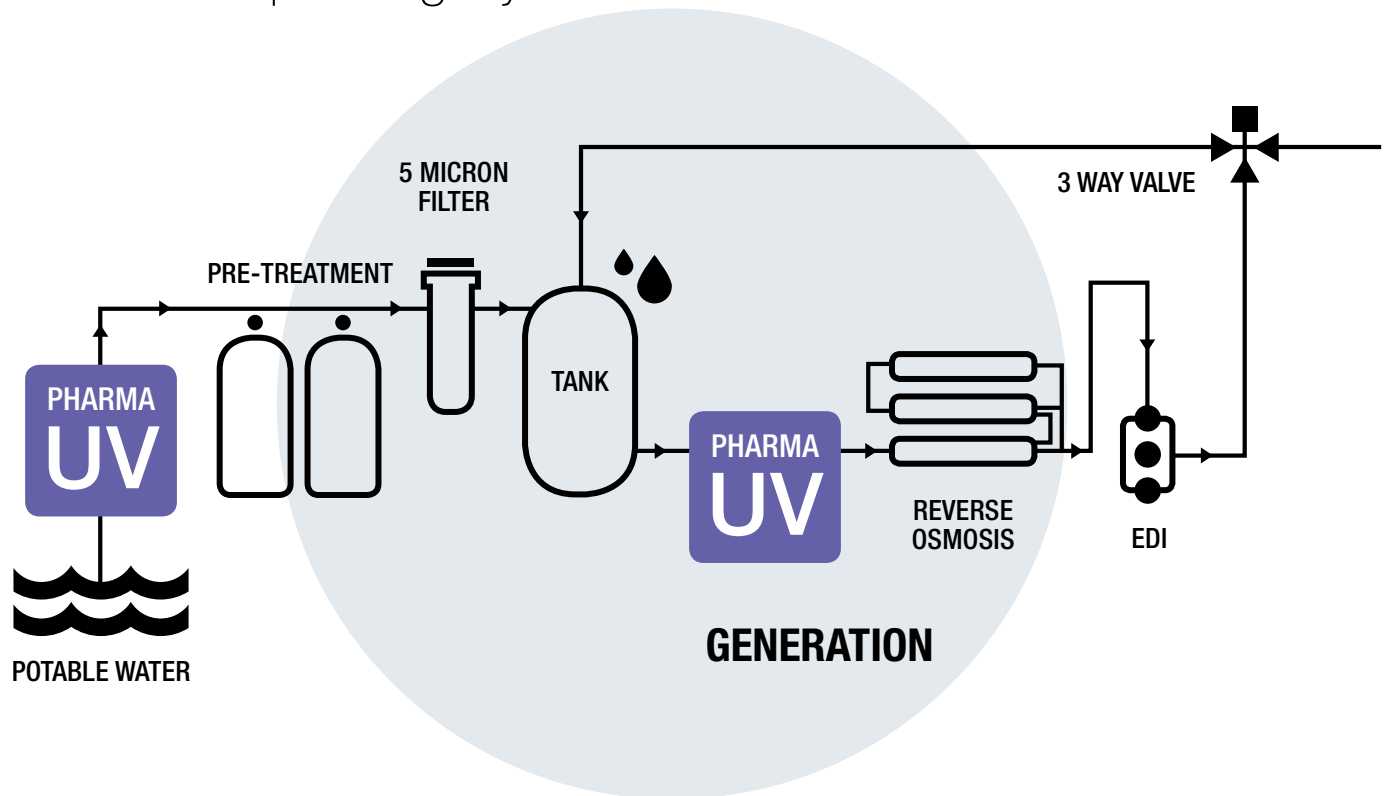

KEY FEATURES	WHAT IT GIVES YOU	BENEFITS FOR YOU
INTELLIGENCE		
Dry DVGW approved UV sensor measuring germicidal wavelengths	Continuous verification of performance with real time RED dose reading and in-built low dose warning	Easy to monitor and log system performance
UVGuard™ on UV sensor window	Protects against UV exposure when checking a UV duty sensor with a reference sensor while the system is operating	Ability to safely audit the UV performance without interrupting production
UVShield™ on chamber*	Indication of lamp on. Power cut out on lamp access. Ability to add water leak detection	UV lamp status on chamber. Enhanced safety for lamp access. Ability to add water leak detection
Flow and UV transmittance (UVT) meter inputs	Dose reading based on actual process conditions when meters are connected	Accurate UV dose reading guaranteed under wide range of operating conditions
Option of using a transmittance compensating third party dose equation	Ability to calculate RED dose compensating for changes in transmittance without a transmittance meter	Accurate UV dose reading guaranteed under wide range of operating conditions without adding a UV transmittance meter
OPTIMIZATION		
Third party validated UV systems tested in accordance with the USEPA UV Disinfection Guidance Manual	UV system dose equations and sizing have been independently derived	Confidence the system will perform as stated
Single low pressure amalgam lamp technology (LPHO)	Targeted microbiological wavelength	Proven log reduction of microorganisms as part of a multi-barrier purified water process Reduced bio-burden in pre-treatment equipment leading to fewer CIP / SIP cycles and optimised production efficiency Protects RO membranes from bio-fouling, reducing CIP frequency and downtime
Designed for pre-treatment processes in the pharmaceutical industry	Flanged connections, standard internal finish FDA-approved materials used for all wetted parts	Reduced system cost where sanitary design is not critical Industry compliant materials
INTEGRATION		
Compact design	Can be fitted to skids Can be retrofitted to existing process	Easy integration
RS 485 Modbus	Single cable connection to customer control system	

*Optional

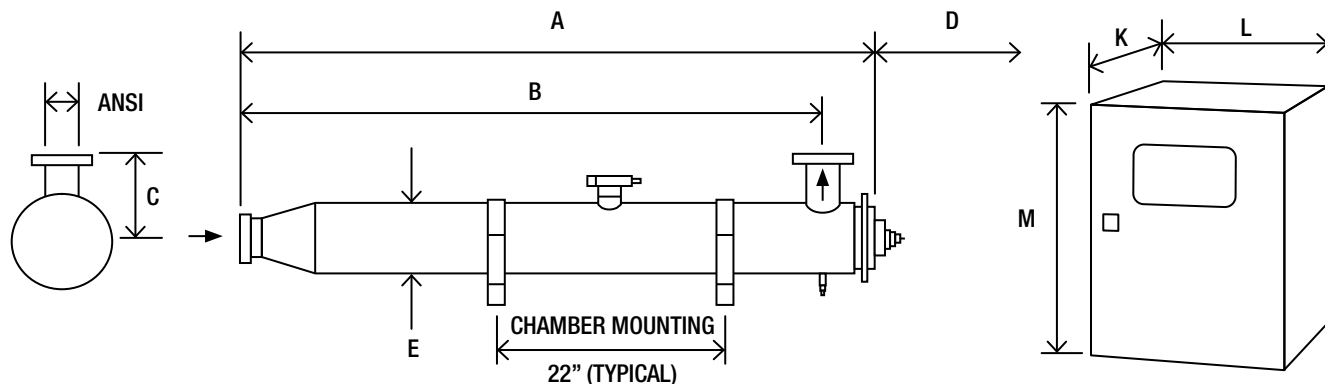

PharmaLine PQ AF (low pressure amalgam lamp)			Dimensions (Inches)									Approx weight (lb)	
Model Number	Maximum Power (W)	Min T ₁₀ (%)	A	B	C	D	E	ANSI	K*	L	M**	Chamber (Empty)	Control Cabinet
PharmaLine PQ AF 0005	125	60	54.6	50.1	3.2	51.2	4	1.6	8.8	23.6	35	19.8	79.3
PharmaLine PQ AF 0008	200	60	54.6	50.1	3.2	51.2	4	1.6	8.8	23.6	35	19.8	79.3
PharmaLine PQ AF 0016	350	60	54.6	50.1	3.2	51.2	4	1.6	8.8	23.6	35	19.8	79.3
PharmaLine PQ AF 0030	350	60	56.6	51.2	6	51.2	6.6	3.1	8.8	23.6	35	53	79.3
PharmaLine PQ AF 0090	750	60	78	71.7	8	75.8	8.1	6	8.8	23.6	35	101.4	79.3

* Allow dimension L in front of cabinet for door opening and panel access.

** M dimension includes the space for the cabinet mounting brackets but you need to allow space below the cabinet for cable entry and access (minimum of 9.8" mm).

All dimensions are approximate for clearance purposes only. We have a policy of continuous product development, exact drawings are available on request. All specifications are subject to change without notification. Your distributor or our account manager can advise on correct sizing and specification requirements.

UV CHAMBER

Material:	StSt 316L / 1.4404
Internal finish:	As made pipe and tube, welds as laid, electropolished and passivated
External finish:	Sateen polish (120 grit) electropolished and passivated
Process (mating) connections:	ANSI 150#
Drain connection:	Tri-clamp to ISO 2852 Table
End plate:	Removable tri-clamp except PQ AF 0090 which is flanged
Degree of protection:	IP65 equivalent to NEMA 4 but not for outside use
Arc tube (lamp):	Low pressure amalgam
Arc tube enclosure:	Pure quartz
Number of arc tubes (lamps):	1
Expected lamp life:	12000 hours
Temperature sensor:	Yes
UV sensor:	Dry DVGW compliant UV sensor with UVGuard™ window
Working fluid temperature:	41°F to 104°F
Maximum CIP temperature:	266°F (PQ AF 0005 – PQ AF 0016) 203°F (PQ AF 0030 – PQ AF 0090) with cabinet electrically isolated
Hydrostatically pressure tested:	Yes to PED requirements EN 13445
Chamber mounting:	Horizontal only
Operating pressure:	10 bar
Seals:	EPDM, FDA 21 CFR 177.2600, USP Class VI 250°F approved

OPTIONS

Transmittance compensating dose equation	
Document Support Pack	
Cabinet material: Stainless steel 304	
Operation and Maintenance manual and printed Installation and Commissioning manual in Chinese, English, French, German and Spanish	
Wiper: Automatic (pneumatically driven)	
Flange options: ANSI 150, JIS, Table 'E' and tri-clamp with chamber internal finish <0.38 µm, welds left as laid, electropolished and passivated	
UVShield™	
Water leak detection	

OPTIONS (CONTINUED)

Lead length: 65.6 ft & 92 ft PQ AF 0005 - 0008, 46 ft PQ AF 0016 - 0090
Maximum CIP temperature: 266°F (panel switched off)
In-field UV reference sensor kit
Welder Document Pack for chamber construction
Bleed: Hygienic valve with tri-clamp connection supplied loose
Skid mounting

CABINET

Material:	Polyester coated carbon steel
Degree of protection:	IP66 / NEMA 4
Supply voltages:	230 V (207 V to 253 V) 50/60 Hz
Operating temperature range:	41°F to 104°F
Relative humidity:	<95% non-condensing
Cooling fans:	No
Interconnecting cable lengths:	32.8 ft
Variable power:	Stepless variable power on PQ AF 0090 only (40% reduction from max ballast power, 20% dose reduction)

HMI / CONTROL

Display:	4 line LCD, indicating system status including alarms
Operating menu:	3 levels with password protection
Fault finding:	Event log

CUSTOMER OUTPUTS

4-20 mA passive outputs:	UV dose or UV intensity
24 V dc 10 mA max outputs:	Lamp ON, any trip, any warning, system ready, system in remote, bleed valve

CUSTOMER INPUTS

4-20 mA passive or active input:	Flow meter and transmittance meter input:
VFC inputs:	Remote stop/start and remote reset

CUSTOMER COMMUNICATIONS PORT

RS 485:	Modbus
---------	--------

APPROVALS

CE marked, UL508A panel shop



PHARMALINE PQ AF

Also available in our Pharmaceutical product range...



PHARMALINE DC

Chlorine removal



PHARMALINE D+DH

Disinfection as part of a multi barrier approach or secondary hygiene maintenance



PHARMALINE DO

Ozone removal and disinfection



berson



hanovia



aquionics

www.weuvcare.com

BERSON, HANOVIA & AQUIONICS WORKING TOGETHER AS PART OF THE HALMA GROUP.

Netherlands

t: +31 40 2907777
e: sales@bersonuv.com

China

t: +86 21 61679599
e: china@hanovia.com

USA

t: +1 980 256 5700
e: sales@aquionics.com

Germany

t: +49 611 44575375
e: verkauf@hanovia.com

Malaysia

t: +60 16 440 8834
e: asia@hanovia.com

Canada

t: +1 980.256.5700
e: sales@aquionics.com

United Kingdom

t: +44 1753 515300
e: sales@hanovia.com

Mexico

t: +1 980.256.5700
e: sales@aquionics.com



A **Halma** company